

Toll free: 888-660-5892  
email: info@truxxx.com

**TIRE FITMENT ADVICE**

The best way to ensure proper tire fitment is to install the kit before purchasing your wheels and tires. Always test fit tires and wheels before purchasing.

**VEHICLE RIDE WARNING!**

Trucks with lift or level kits installed have a higher center of gravity. Aggressive and sudden direction changes may cause a tip over.

**108030 Ford F250/350/Excursion SuperDuty 4x4 Level Kit**

This kit contains:  
2 - Spring Spacers  
2 - Shock Brackets  
1 - Hardware Pack  
Instructions  
Warranty Card  
Stickers



**Installation Tips**

**Always use caution handling ABS or wheel sensor wiring. Avoid tension of any kind on wiring harness as this may cause damage or failure.**

1. Trucks are often not level side to side from the factory. Please measure before installation.
2. Re-torque all hardware to manufactures specifications
3. When aligning, to get the best tire wear use our supplied specifications. OEM specifications are for trucks with stock wheels and tires. Larger tires will wear differently.
4. All instructions are written with vehicle on a 2-post lift with tires removed.

**Step 1**

Support the front differential with a pit jack or similar. Disconnect the front shocks and sway bar links. Disconnect the brake line mounts and any ABS wiring brackets.

**Step 2**

Lower the front differential allowing access to the top of the spring. Remove the OEM rubber isolator and install it on the TRUXXX spacer over the cone and install the spacer on top of the spring as shown in Figure A.

**Step 3**

Install the TRUXXX shock brackets on the bottom of the shocks. Elevate the differential into position and reconnect shocks, sway bar links, brake line mounts and any ABS wiring.

**Alignment notes:**

We recommend that a technician with experience doing alignments on lifted trucks perform the alignment. Large tires wear differently than OEM sized tires. Always do an alignment after changing tires on a vehicle.

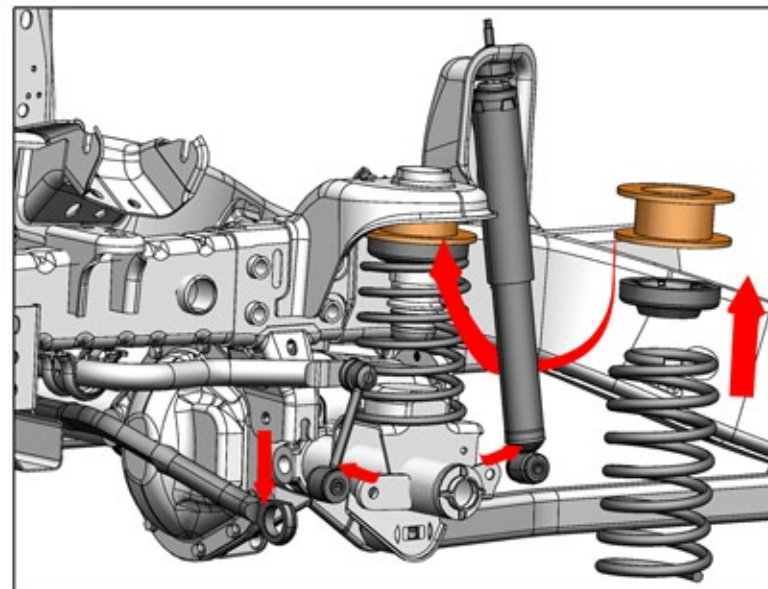

**Figure A:** Illustration is for reference only. Part dimensions will vary from kit to kit.

	Left	Right
Caster (degrees)	1.5	1.5
Camber (degrees)	-1/4 or -.25	-1/4 or -.25
Toe	1/32" or .03125 toe in	
Special Tools	none	