

Toll free: 888-660-5892
email: info@truxxx.com

TIRE FITMENT ADVICE
The best way to ensure proper tire fitment is to install the kit before purchasing your wheels and tires. Always test fit tires and wheels before purchasing.

VEHICLE RIDE WARNING!
Trucks with lift or level kits installed have a higher center of gravity. Aggressive and sudden direction changes may cause a tip over.

403010 HUMMER H3, Chevrolet Colorado, GMC Canyon Lift and Level Kit

- This kit contains:
 2 - Torsion
 2 - Shock Brackets
 1 - Hardware Pack
 Instructions
 Warranty card
 Stickers



Installation Tips

Always use caution handling ABS or wheel sensor wiring. Avoid tension of any kind on wiring harness as this may cause damage or failure.

1. Trucks are often not level side to side from the factory. Please measure before installation.
2. Re-torque all hardware to manufactures specifications
3. When aligning, to get the best tire wear use our supplied specifications. OEM specifications are for trucks with stock wheels and tires. Larger tires will wear differently.
4. All instructions are written with vehicle on a 2-post lift with tires removed.

Step 1

Remove Torsion Adjuster bolt completely. Place 1" sleeve spacer over stock adjuster bolt and reinstall.

Step 2

Install the shock extensions using supplied hardware. **Note:** shock extensions are not used on Chevrolet Colorado/ GMC Canyon

Step 3

Reinstall tires and lower vehicle to the ground to set proper height.

Special Note On H3 Hummer Ride Height:

It is necessary to check and reset the proper ride height after test driving the vehicle. Failure to set the ride height correctly could cause premature CV joint, tie rod and ball joint wear. The correct ride height is measured from the center of the front wheel to the fender, and should be 24.25"

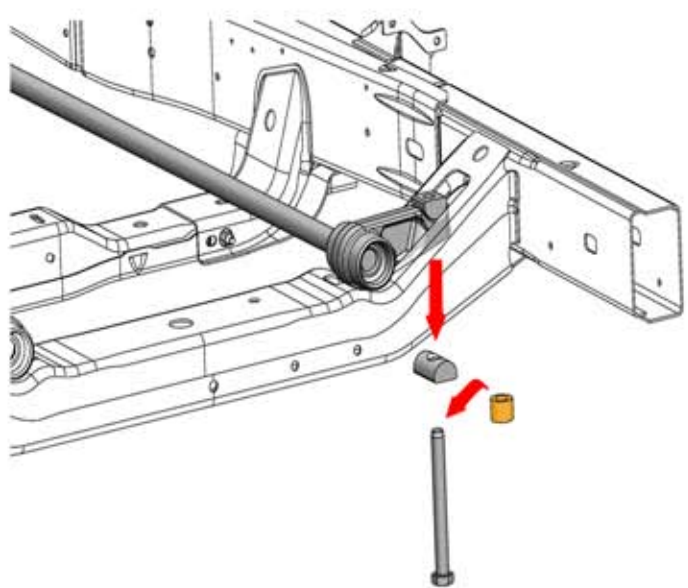

Alignment notes:
We recommend that a technician with experience doing alignments on lifted trucks perform the alignment. Large tires wear differently than OEM sized tires. Always do an alignment after changing tires on a vehicle.

	Left	Right
Caster (degrees)	1.5	2
Camber (degrees)	0	-.250
Toe	.0312 or 1/32" toe in	
Special Tools	none	